

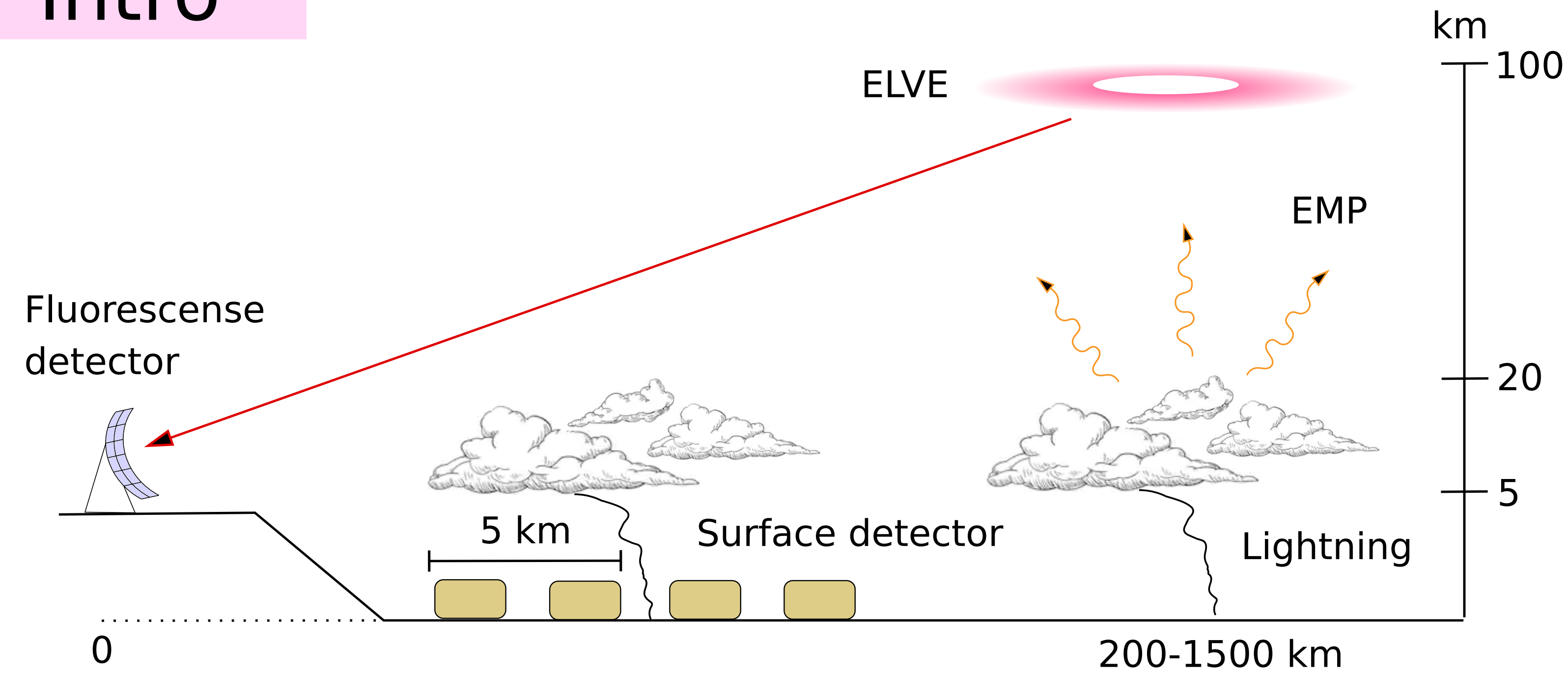

## Intro

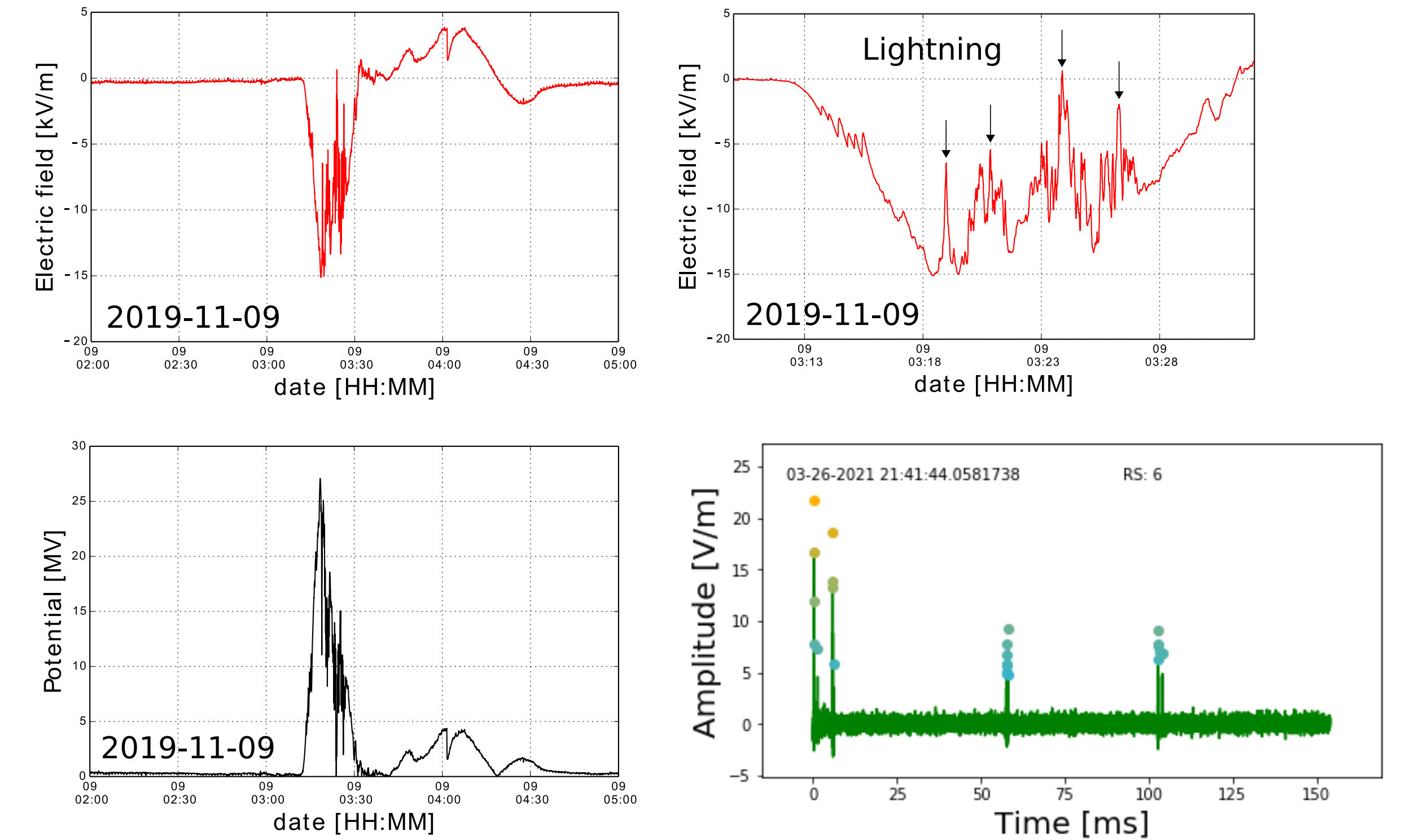

## Results

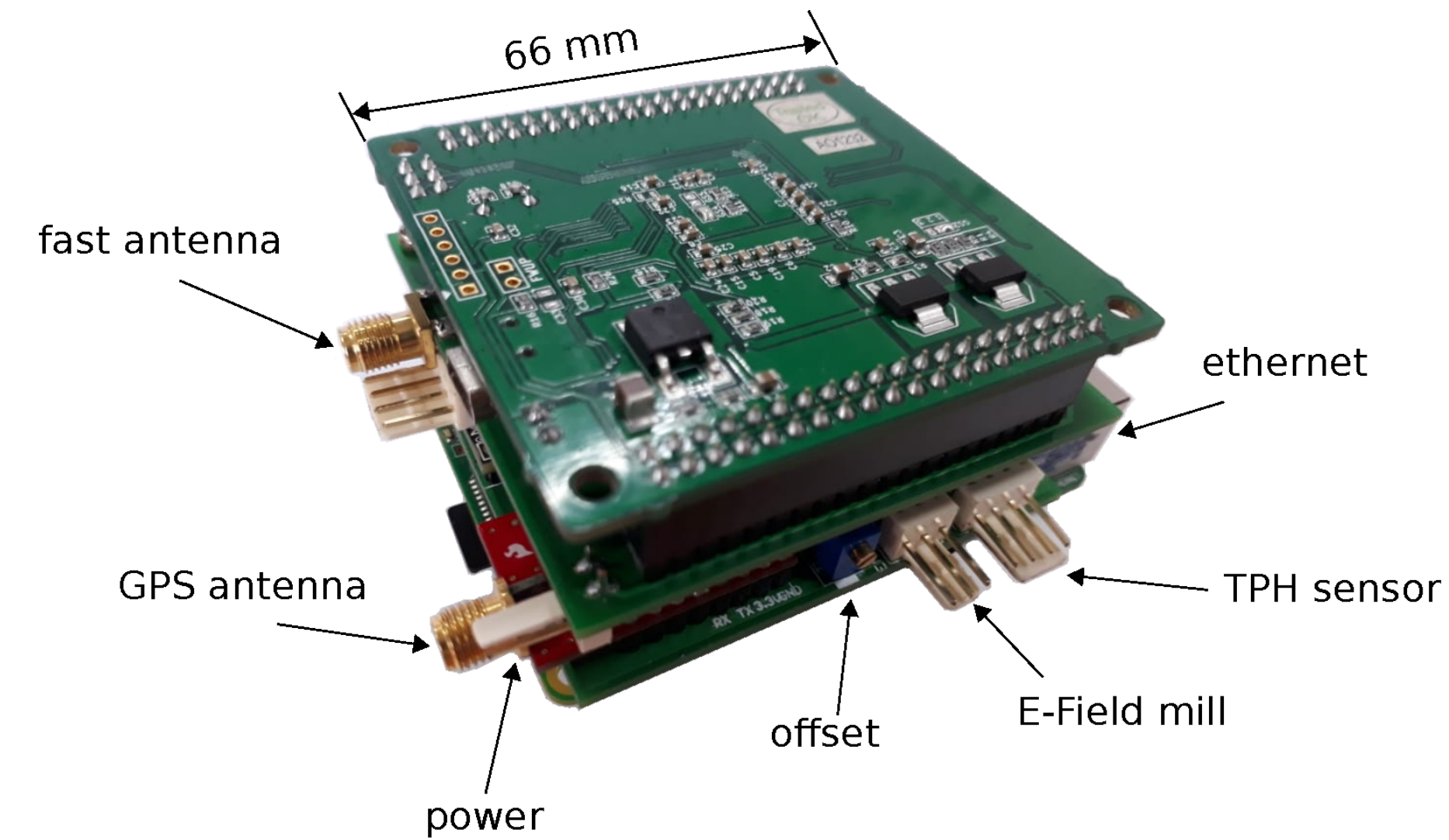

## Hardware

\*jesus.pena@correo.uis.edu.co

### Quasi-static electric field

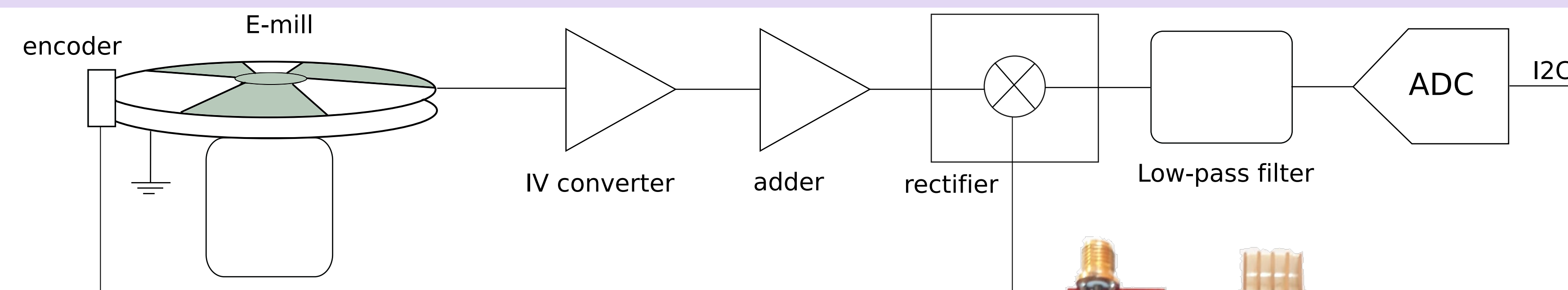

Range 0-500 kV/m  
Resolution 500 mV/m (20-bit ADC)  
Frequency 100 Hz

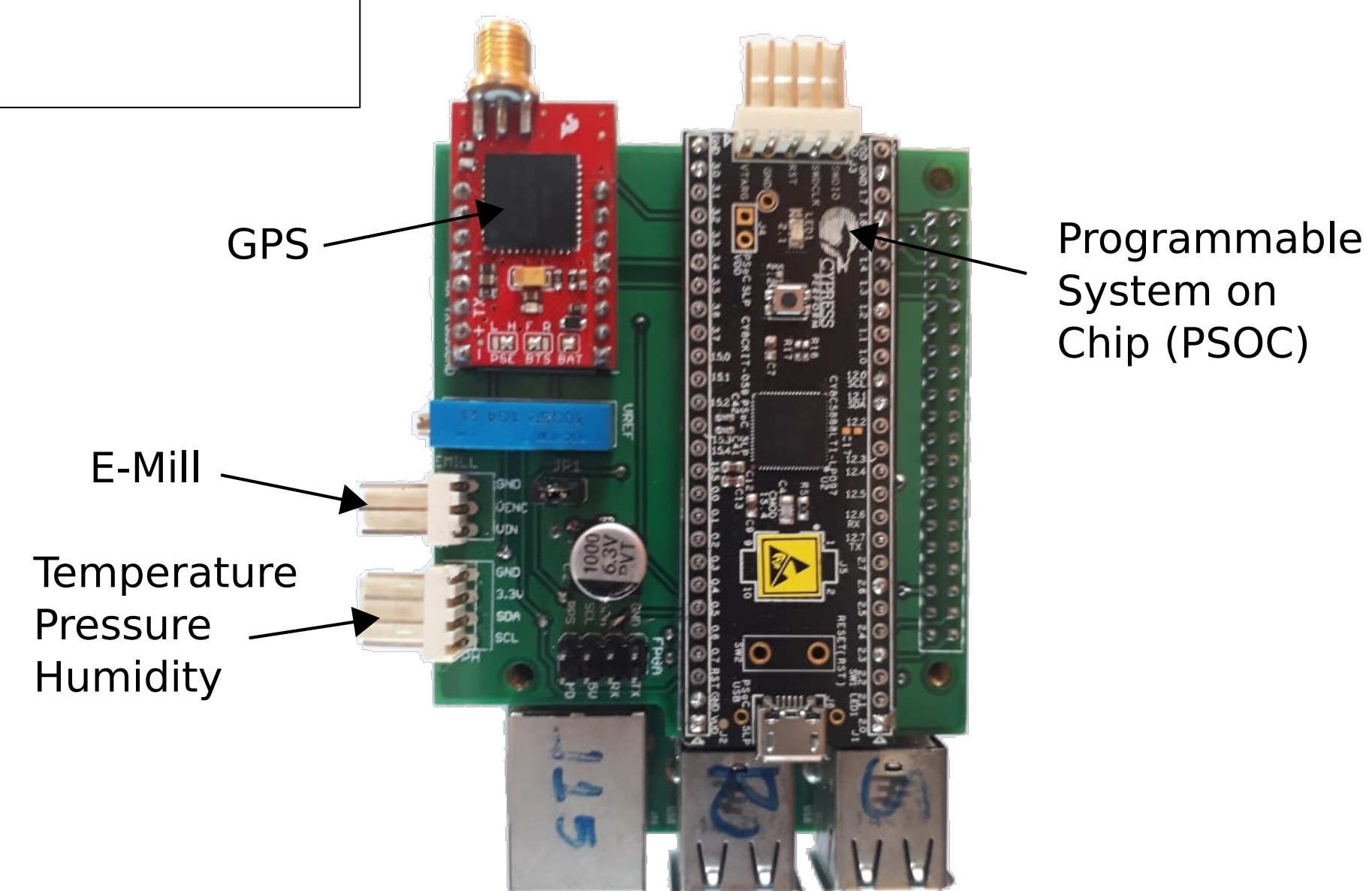

### Lightning

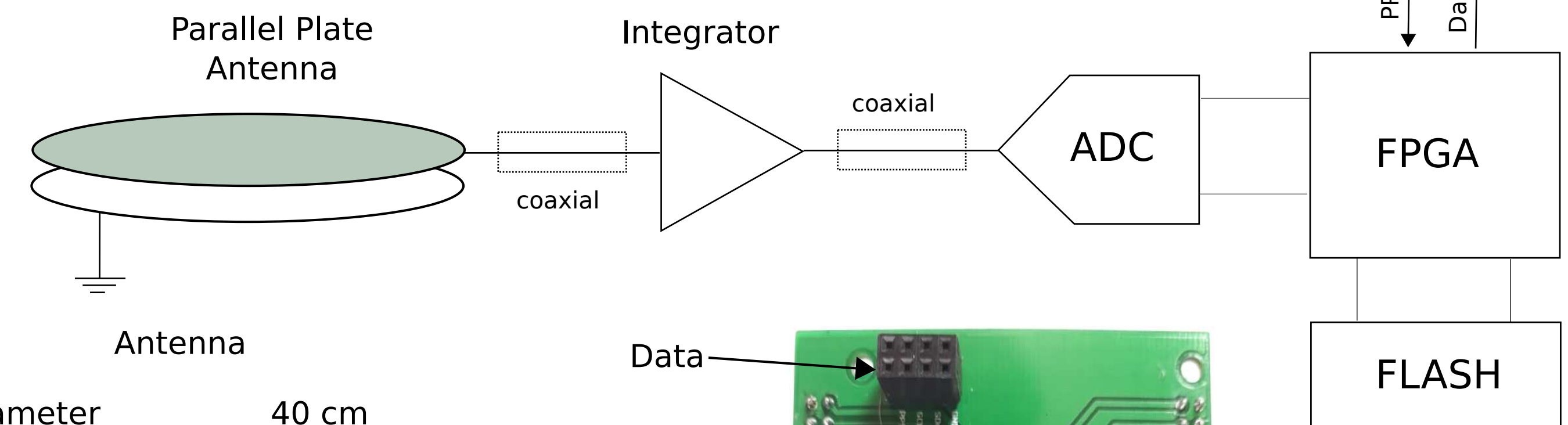

Antenna  
Diameter 40 cm  
Delay time 0.13 ms  
Frequency cut 31 MHz

DAQ  
Range 0 - 2 V  
Resolution 12 bits  
S. frequency 100 kHz  
Recording length 1.2 s  
pre-trigger 100 us  
post-trigger 800 ms

